



ELECTRIC TWO COMPARTMENT CONVECTION STEAMER ON CABINET BASE



Model SX-34EC

- SX-34EC
- SX-55EC

OPERATION SHALL BE BY:

Electrically heated steam generator operating at 0 psi (0 kPa) with field replaceable elements rated at:

- SX-34EC - 7.5 kW + 10 kW
- SX-55EC - 15 kW + 15 kW (optional 12kW + 12kW)

The generator shall be equipped for operation on:

- 208 VAC, 3 Phase, 50/60 Hz
- 220 VAC, 3 Phase, 50/60 Hz
- 240 VAC, 3 Phase, 50/60 Hz
- 380/220 VAC, 3 Phase, 50/60 Hz, 4 wire

STANDARD FEATURES:

- Water Treatment System
- Automatic blow down
- Split water connection
- 316 stainless steel interior with coved corners

OPTIONS & ACCESSORIES AT ADDITIONAL COST

- | | | |
|--|---|--|
| <input type="checkbox"/> 380 VAC, 3 Phase, 50/60 Hz (SEVS-1) | <input type="checkbox"/> Continuous Steam Mode (CSF-) | <input type="checkbox"/> Single pantry spray hose and bracket (SP-RSH) |
| <input type="checkbox"/> 480 VAC, 3 Phase, 50/60 Hz (SEVS-2) | <input type="checkbox"/> Load Compensated timers (LCT-2) | <input type="checkbox"/> Double pantry spray hose and bracket (DP-RSH) |
| <input type="checkbox"/> 575 or 600 VAC, 3 Phase, 60Hz (specify) (SEVS-3) | <input type="checkbox"/> Correctional package | |
| <input type="checkbox"/> 120 minute timers | <input type="checkbox"/> Pan guides in cabinet (SX-34EC only)(SEPG-1) | |
| <input type="checkbox"/> High sensitivity level controls (R.O. water) (HSB-) | | |

STANDARD CONSTRUCTION SPECIFICATIONS

Shall be a Crown model SX-34EC or SX-55EC, convection steamer with individual electric steam generators for each cavity, c-CSA-us and NSF Certified.

The steamer shall be constructed of #4 finish stainless steel, type 304.

The cooking chamber is a one piece all welded, type 316 stainless steel with coved corners.

The heavy duty door shall have an inner liner of stainless steel, with a full perimeter gasket seal, an outer liner of one piece all welded stainless steel, and a positive lock and seal mechanism with spring release.

Each compartment shall be provided with removable stainless steel pan supports.

A stainless steel drip trough shall be integrally connected to the drain to collect condensate when the doors are opened.

The control housing shall be constructed of stainless steel with a full access removable panel.

The controls shall include an illuminated three way power switch (On/Off/Delime), a pilot ready light, a pilot cooking light, a 60 minute electric timer which sounds an audible signal at the end of the cooking cycle and solid state generator controls.

Steam flow to the cooking chamber shall be cut off when the door is opened and reactivated when the door is closed.

Standard features include a water treatment system, automatic generator blow down, de-lime mode power setting, de-lime port located at the rear of the unit for each generator, and split water connections for simple hook up for a treated water system.

The steamer shall be mounted on 23" high (for 10 pan), or 28" high (for 7 pan) with all stainless steel constructed cabinet base with operable door for storage and 6" high stainless steel legs fitted with 4 adjustable flanged feet for floor anchoring.

SEE REVERSE SIDE OF SPEC SHEET FOR WATER TREATMENT SYSTEM STATEMENTS



Approval Notes: _____

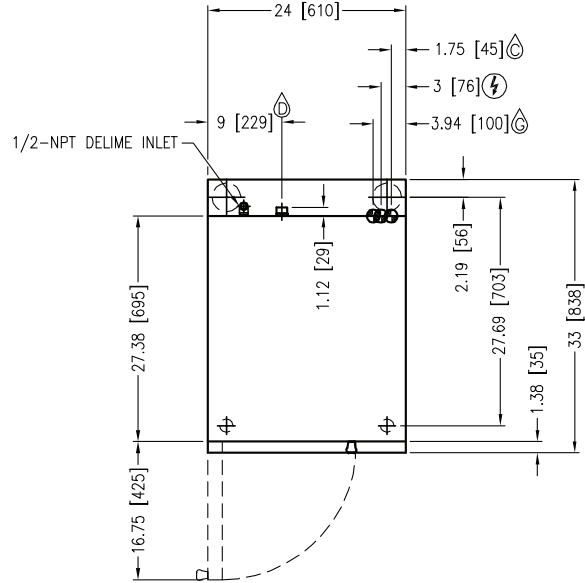
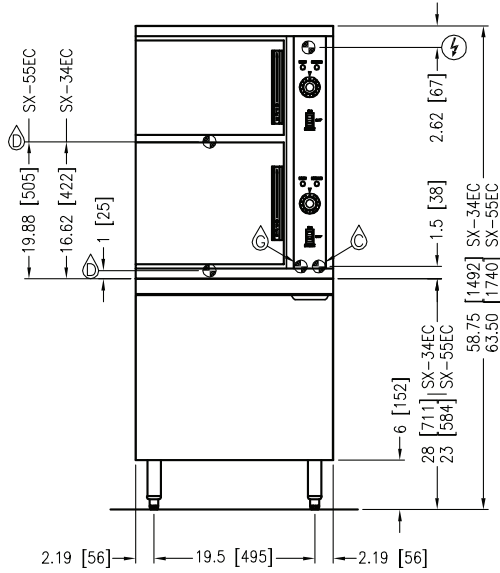
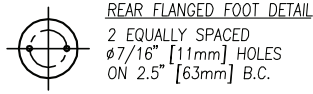

SERVICE CONNECTIONS

- ELECTRICAL CONNECTION: 1 1/8" hole for electrical connection. Rating to be as specified on data plate.
- DRAIN: 1" IPS piped to open floor drain. No Solid Connection. 24" length before open air gap opening (no bends or elbows)
- GENERATOR WATER: 3/8" O.D. tubing at 25-50 PSI (170-345 kPa)
- CONDENSATE COLD WATER: 3/8" O.D. tubing at 25-50 PSI (170-345 kPa)

ELECTRICAL CHARACTERISTICS

MODEL	KW	PHASE	AMPS PER LINE				
			208V	220V	240V	380V	480V
SX-34EC	17.5 standard	3	49	46	42	26.6	21.1
	24 optional	3	66.6	63	57.8	36.5	28.9
SX-55EC	30 standard	3	83.3	78.7	72.2	45.6	36.1

COMPARTMENT PAN CAPACITY

Model	Compartments	Capacity
SX-34EC	2	1-7 Pans
SX-55EC	2	1-10 Pans

WATER QUALITY STATEMENT

Water is the essential ingredient in steam equipment, water quality is the major factor affecting the performance of your appliance. Crown Steam Group offers a Comprehensive Water Treatment System which exceeds our minimum water requirements. Proof of installation and proper cartridges replacement is required for warranty coverage. Water supply to Crown Steam Group steamers must be within these guidelines.

- Total dissolved solids Less than 60 PPM
- Total alkalinity Less than 20 PPM
- Silica Less than 13 PPM
- Chlorine Less than 1.5 PPM
- pH Factor 6.8 - 7.3

Water which does not meet these standards should be treated with the installation of Middleby's Water Treatment System. Call 919-762-1000 if you have questions concerning your water meeting these parameters.

*Failure or malfunction of this appliance due to poor water quality is not covered under warranty.
 Reference www.crownsteamgroup.com for complete warranty details and instructions.

**INTENDED FOR COMMERCIAL USE ONLY.
 NOT FOR HOUSEHOLD USE.**

